

AURORA MODEL 650 PUMP SPLIT PACKING BOX OPTION

SECTION 650 PAGE 165

DATED NOVEMBER 1988

POWER FRAMES 4 & 5 ONLY



Optional Split Packing Box
With Leakage Accumulator
Gland Illustrated

Split packing boxes separate vertically through the packing insert to simplify packing replacement and shaft sleeve inspection. The insert halves are dowed, register aligned and gasketed to prevent leakage. Only six bolts need be removed to expose all of the packing and lantern ring. Remove two more bolts and the remaining packing box insert half can be removed.

The completely exposed packing and sleeve area coupled with the extra large access openings in the pump adapter provides the ultimate in packing accessibility.

Five (5) die-molded, diagonally split, packing rings complete with lantern ring line the stuffing box. The general service packing consists of graphited fiber.

The stuffing box length, bore, sleeve diameters and lantern ring width conform with the recommended standard of the Mechanical Packing Association (MPA).

A tapped opening is provided for lubricating the stuffing box. Lubrication is accomplished by adding grease directly into the lantern ring cavity through a grease fitting or by connecting a by-pass line between the pump discharge and the stuffing box. Automatic grease seals as well as other flushing options are also available.

The standard 450 minimum brinell hardened stainless steel shaft sleeve extends through the entire length of the box and gland and is provided with a snap ring. This snap ring design allows the sleeve and the completely assembled packing box to be removed intact. Reassembly can be accomplished in the same manner. Assemble the complete stuffing box at the convenience of the work bench, install and adjust the packing for proper lubrication leakage (5-10 drops per minute after run-in).

LEAKAGE ACCUMULATOR

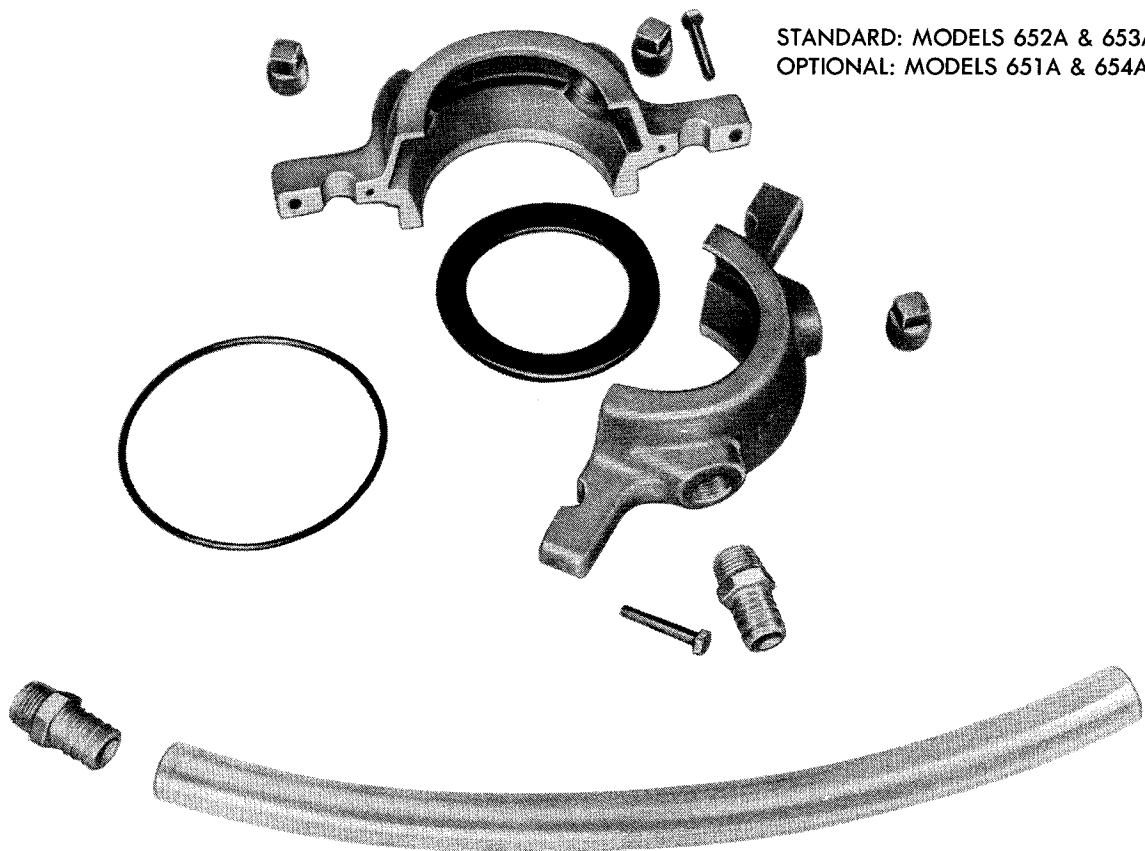

STANDARD: MODELS 652A & 653A
OPTIONAL: MODELS 651A & 654A

The leakage accumulator gland (sprayless, dripless packing gland) is designed and constructed to prevent the collection of packing leakage in the pump bracket of a vertical or horizontally mounted pump. The leakage accumulator gland has a volute shape with two symmetrical halves. This gland encloses the water slinger preventing any spray from escaping and contaminating the area. The leakage is efficiently directed to a drain connection.

The two gland halves are doweled, bolted together, and sealed at the parting line with a soft liquid sealant. An "O" ring seal between the gland and packing box prevents any leakage in this area. One of the pipe tap ports on the side of the gland is fitted with a hose connector and a clear plastic section of hose, to both drain off and allow visual inspection of the leakage. The remaining ports have pipe plugs, but may be used for maintenance purposes to flush & drain debris from the accumulator.

AURORA MODEL 650 PUMP DOUBLE MECHANICAL SEAL

SECTION 650 PAGE 167

DATED NOVEMBER 1988

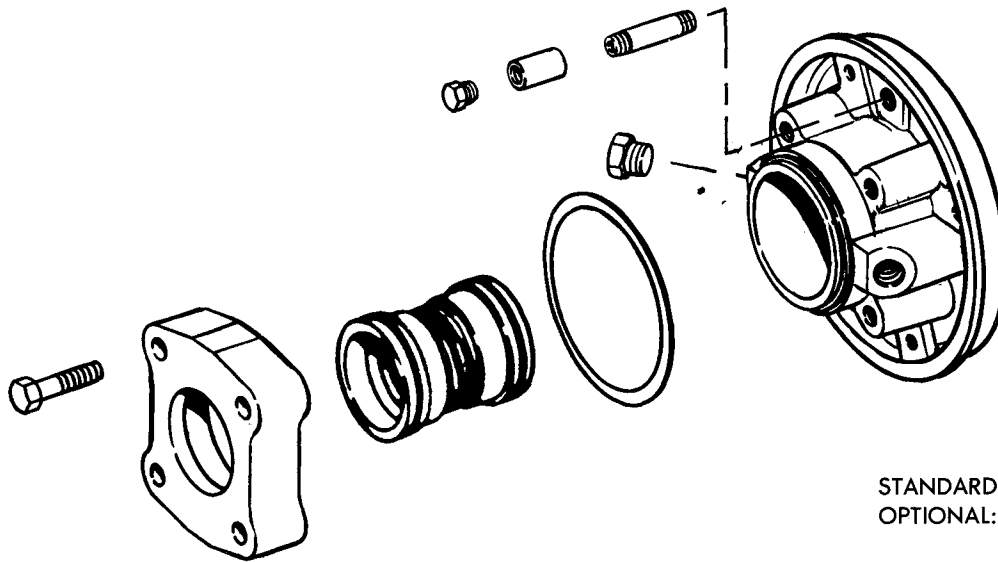

STANDARD: MODEL 654A
OPTIONAL: MODELS 651A, 652A & 653A

Double mechanical seals are recommended for gritty or abrasive applications. Seal faces are protected by clear water under pressure, injected directly into the seal cavity. Pressure in the seal box must be fifteen (15) lbs. higher than the operating pressure at the stuffing box of the pump. This forces the inner sealing faces closed and provides both faces with a film of clear sealant. If this is not done, abrasive particles may be forced under the sealing faces hastening wear. Even when the pump is not running, a pressure differential, or at least equal pressure in the seal box, is desirable. The sealant circulation for most pumping operations may be dead ended in the stuffing box. Pressures over 30 psi or RPM of 1200 max. require constant circulation to prevent overheating.

The seal box is designed for the compressed seal length and does not require any adjustments. The seal housing is extra large to provide excellent circulation of clear sealing liquid. The housing also has two tapped openings 180° apart for the flushing connections.

The standard shaft sleeve design is provided with a snap ring which allows the sleeve and the completely assembled seal box to be removed intact. Reassembly can be accomplished in the same manner. Assemble the complete seal box at the convenience of the work bench and install.

SHAFTS

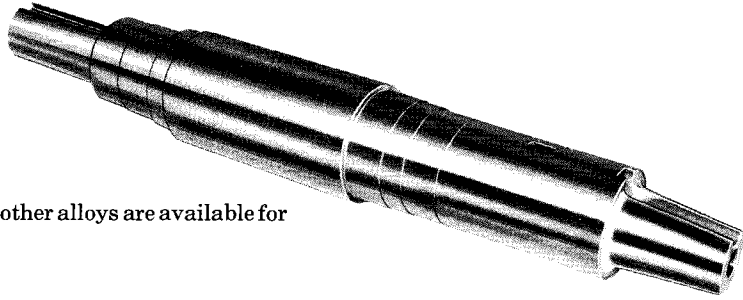

Precision machined shafts of stainless steel, monel and other alloys are available for difficult application.

SLEEVES

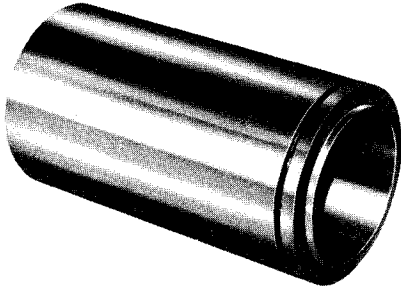

Shaft sleeves, machined to close tolerances are optionally available in either bronze, 316 stainless steel, or monel.

WEAR RINGS

Replaceable stainless steel wear rings available individually or together, protect the impeller and/or casing from wear. The rings are secured and aligned by 4 flat head machine screws that are easily removed. The ring running clearances are adjusted externally by the bearing cap. External flushing of the ring faces is available.

